

.LINEA HARMONIS

ARMADI | COMODINI | TAVOLI

ARREDO SANITARIO

2026

Le immagini riprodotte in questa scheda sono puramente indicative e i valori dimensionali sono nominali.

È facoltà del produttore apportare ai progetti modifiche senza alcun preavviso.





ARMADI



COMODINI



TAVOLI

.LINEA HARMONIS

.LINEA HARMONIS
.ARMADI



Armadi ospedalieri con ripiani e vani progettati per organizzare in modo pratico ed efficiente indumenti, scarpe e oggetti personali.
Realizzati con pannelli in agglomerato di particelle di legno, disponibili in un'ampia gamma di finiture.



ARMADI .LINEA HARMONIS

FINITURE

S STRUTTURA



BIANCO

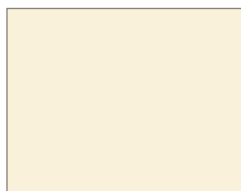

CORDA



CANAPA

A ANTA



BIANCO

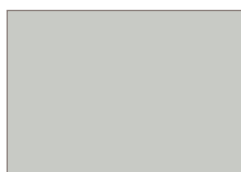

GRIGIO

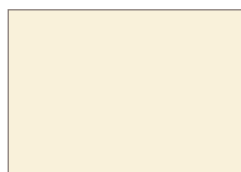

CORDA



CANAPA



VISIONE



GRAFITE



LICHENE



DENIM



CIELO



BLU



MENTA



ROVERE GESSATO



SENAPE



MANDARINO



CORALLO

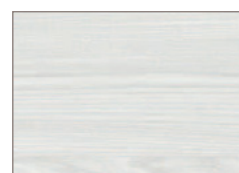

FRASSINO NUVOLA



NOCE MAT



NOCE SMOKE



ROVERE RIGATO



ROVERE MAINE

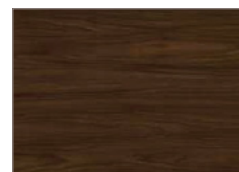

NOCE MOKA

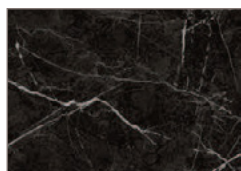

MARMO NERO MARQUINIA

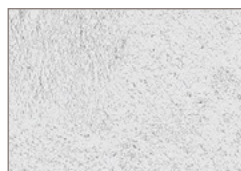

CALCE PERLA



CALCE CENERE



CORTEN BERICO



MARMO CANOVA

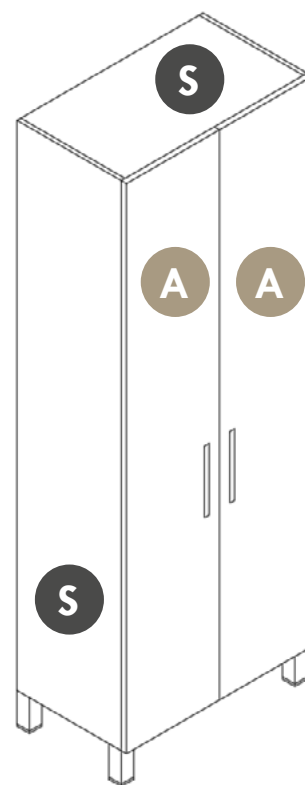

CARATTERISTICHE TECNICHE

- **STRUTTURA:** realizzata con pannelli in agglomerato di particelle di legno (UNI EN 309) sp. 18 mm in classe E1 a bassa emissione di formaldeide, nobilitati in melamminico 2 lati con finitura anti-graffio. Bordo 3 lati carta e profilo frontale provvisto di profilo parapolvere e antirumore.
- **SCHIENA** realizzata con pannello di fibra di legno nobilitato sp. 6 mm (di serie) o sp.12 mm (con maggiorazione).
- **ANTE** realizzati con pannelli in agglomerato di particelle di legno (UNI EN 309) sp. 18 mm in classe E1 a bassa emissione di formaldeide, nobilitati in melamminico 2 lati con finitura antigraffio. Bordi perimetrali in ABS raggato antinfortuio. Le ante montano cerniere con montaggio rapido a vite eccentrica, regolabili nelle 3 direzioni.
- **CERNIERE** con chiusura rallentata in acciaio con riporto galvanico di rame e nichel, dotate di tre regolazioni. Resistenza garantita oltre i 100.000 cicli di apertura/chiusura.
- **RIPIANI INTERNI:** realizzati con pannelli in agglomerato di particelle di legno (UNI EN 309) sp. 18 mm in classe E1 a bassa emissione di formaldeide, nobilitati in melamminico 2 lati con finitura antigraffio. Bordo 3 lati carta e prolo frontale in ABS raggato antinfortuio. Fissaggio mediante reggi ripiano.
- **SERRATURE:** a cilindro con catenaccio. Predisposta per l'estrazione del nottolino che ne consente una sostituzione rapida senza cambiare interamente la serratura. Le due chiavi sono pieghevoli con presa in materiale plastico. Optional: chiave passepartout. In alternativa serratura a cilindro con asta rotante, fissata su coperchio e fondo. Predisposta per l'estrazione del nottolino che ne consente una sostituzione rapida senza cambiare interamente la serratura.
- **ASTA APPENDIABITI:** realizzata in tubo ovale dim. 30x15 mm, supporti laterali in zama fissati all'interno della struttura. Finitura cromata.

1 ANTA



COD. GBW00001
ARMADIO A 1 ANTA
L450 X P520 X H1910 mm

2 ANTE



COD. GBW00002
ARMADIO A 2 ANTE
L900 X P520 X H1910 mm

PIEDINI LIVELLATORI

PIEDE CILINDRICO
Diametro 60 mm - Altezza 150 mm



VERNICIATO ALLUMINIO

MANIGLIA

AD ARCO
alluminio anodizzato - passo: 224 mm





COMPONENTI OPZIONALI

Grazie a una progettazione funzionale, ogni elemento può essere arricchito con accessori compatibili, studiati per integrarsi tra loro. Questa modularità permette di rispondere a esigenze specifiche, migliorando l'efficienza e la praticità dell'articolo.

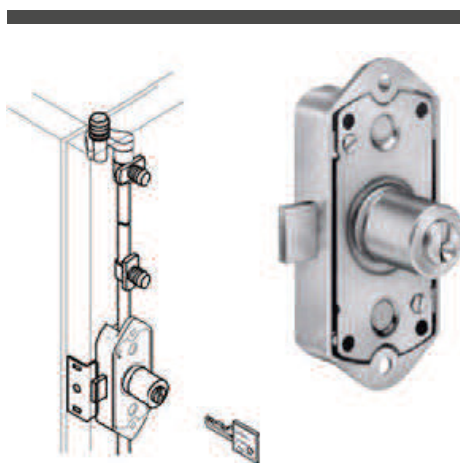

COD. GBW00003
SERRATURA CON ASTE ROTANTI
con predisposizione chiave Passe-partout



.LINEA HARMONIS
COMODINI



Comodini ospedalieri pratici e funzionali, progettati per organizzare in modo efficiente effetti personali, oggetti di uso quotidiano e piccoli indumenti. Struttura realizzata con pannelli in agglomerato di particelle di legno, disponibili in un'ampia gamma di finiture per adattarsi a ogni ambiente sanitario. Dotati di guide scorrevoli su rullini con profili chiusi, che assicurano uno scorrimento fluido e silenzioso.

SU PIEDINI



SU RUOTE



COMODINI

.LINEA HARMONIS

FINITURE

S STRUTTURA



BIANCO

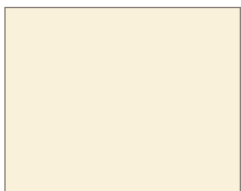

CORDA

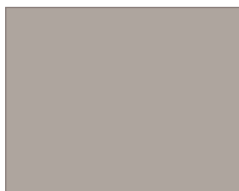

CANAPA

A ANTA



BIANCO

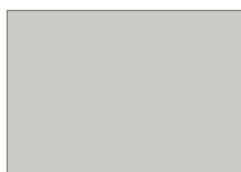

GRIGIO

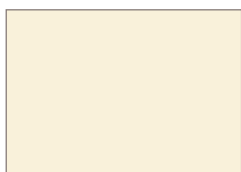

CORDA



CANAPA



VISIONE



GRAFITE



LICHENE



DENIM



CIELO



BLU



MENTA



ROVERE GESSATO



SENAPE



MANDARINO



CORALLO

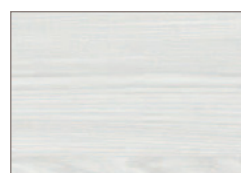

FRASSINO NUVOLA



NOCE MAT



NOCE SMOKE



ROVERE RIGATO



ROVERE MAINE

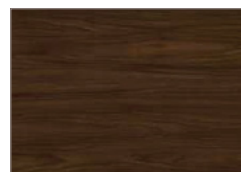

NOCE MOKA

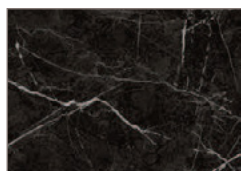

MARMO NERO MARQUINIA



CALCE PERLA



CALCE CENERE



CORTEN BERICO



MARMO CANOVA

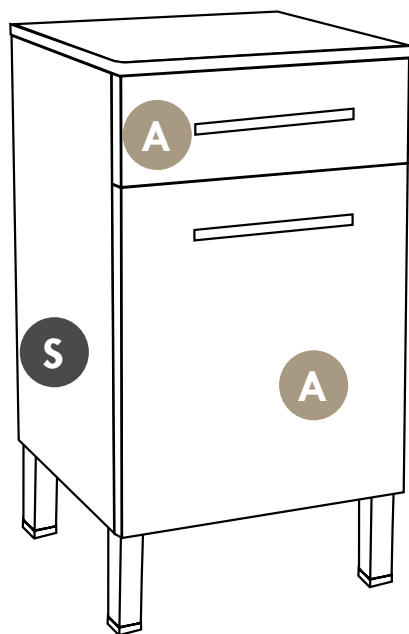

CARATTERISTICHE TECNICHE

- **STRUTTURA:** realizzata con pannelli in agglomerato di particelle di legno (UNI EN 309) sp. 18 mm in classe E1 a bassa emissione di formaldeide, nobilitati in melamminico 2 lati con finitura antigraffio. Bordo 3 lati carta e profilo frontale provvisto di profilo parapolvere e antirumore.
- **SCHIENA** realizzata con pannello di fibra di legno nobilitato sp. 6 mm (di serie) o sp. 12 mm (con maggioranza).
- **CASSETTI:** sponde cassette realizzate con pannelli in agglomerato di particelle di legno sp. 12 mm nobilitato in melamminico. Fondo di fibra sp. 4 mm in particelle di legno, classe E1 a bassa emissione di formaldeide. Di serie guide scorrevoli su rullino con prolli chiusi per lo scorrimento guidato. Doppio fermo in uscita che permette il blocco del cassetto in posizione aperta, versione non rallentata ad estrazione parziale con portata dinamica di 20 kg. In alternativa guide scorrevoli con fermo di fine corsa e sistema ad incastro per bloccaggio antisganciamento tipo quadro, versione rallentata ad estrazione totale con portata dinamica di 45 kg.
- **ANTE** realizzati con pannelli in agglomerato di particelle di legno (UNI EN 309) sp. 18 mm in classe E1 a bassa emissione di formaldeide, nobilitati in melamminico 2 lati con finitura antigraffio. Bordi perimetrali in ABS raggiato antinfortuno. Le ante montano cerniere con montaggio rapido a vite eccentrica, regolabili nelle 3 direzioni.
- **CERNIERE** con chiusura rallentata in acciaio con riporto galvanico di rame e nichel, dotate di tre regolazioni. Resistenza garantita oltre i 100.000 cicli di apertura/chiusura.
- **RIPIANI INTERNI:** realizzati con pannelli in agglomerato di particelle di legno (UNI EN 309) sp. 18 mm in classe E1 a bassa emissione di formaldeide, nobilitati in melamminico 2 lati con finitura antigraffio. Bordo 3 lati carta e profilo frontale in ABS raggiato antinfortuno. Fissaggio mediante reggi ripiano.
- **SERRATURE:** a cilindro con catenaccio. Predisposta per l'estrazione del nottolino che ne consente una sostituzione rapida senza cambiare interamente la serratura. Le due chiavi sono pieghevoli con presa in materiale plastico. Optional: chiave passepartout. In alternativa serratura a cilindro con asta rotante, fissata su coperchio e fondo. Predisposta per l'estrazione del nottolino che ne consente una sostituzione rapida senza cambiare interamente la serratura.



**COD. GBW0004**

COMODINO SU PIEDINI CON ANTA
E CASSETTO
L450 X P461 X H808 mm

**COD. GBW0005**

COMODINO SU PIEDINI CON ANTA,
RIPIANO E CASSETTO
L450 X P461 X H808 mm

**COD. GBW0006**

COMODINO SU RUOTE CON ANTA
E CASSETTO
L450 X P461 X H754 mm

**COD. GBW0007**

COMODINO SU RUOTE CON ANTA,
RIPIANO E CASSETTO
L450 X P461 X H754 mm

PIEDINI LIVELLATORI

PIEDE CILINDRICO

Diametro 60 mm - Altezza 150 mm

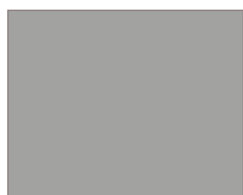

VERNICIATO ALLUMINIO

RUOTE

Diametro 75 mm - Altezza Sottobase 96 mm

Finitura grigio - Gommate antitraccia



MANIGLIA

AD ARCO

alluminio anodizzato - passo: 224 mm

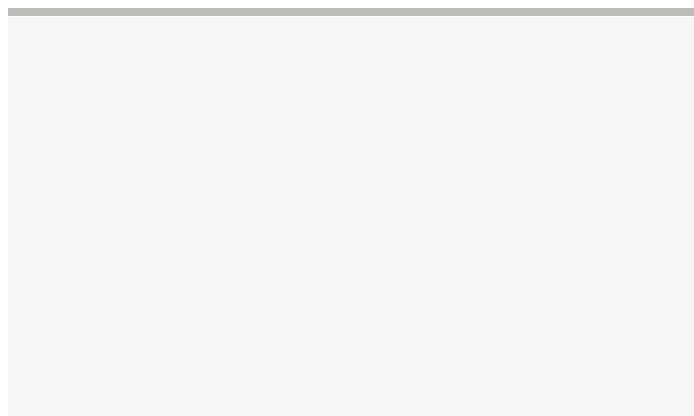

A photograph of a dining area with a long, thin table and a modern chair. In the background, there is a large wardrobe and a framed picture on the wall. The entire image is overlaid with a semi-transparent green filter.

.LINEA HARMONIS
TAVOLI



Tavoli dal design minimalista con piano in agglomerato di particelle di legno nobilitato sp. 25 e bordato in ABS, angoli raggianti e gambe in acciaio a sezione circolare, accessibili con carrozzina.

ROTONDO



QUADRATO



.LINEA HARMONIS

FINITURE



BIANCO



CORDA

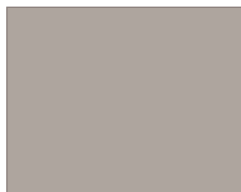

CANAPA



VISONE



GRAFITE

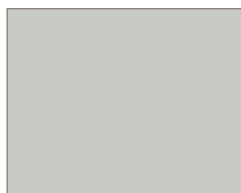

GRIGIO



DENIM



CIELO



BLU



MENTA



LICHENE



SENAPE



MANDARINO



CORALLO



FRASSINO NUVOLA



ROVERE GESSATO



NOCE SMOKE



ROVERE RIGATO



ROVERE MAINE

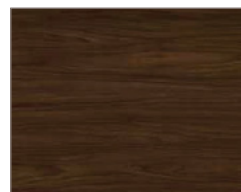

NOCE MOKA



NOCE MAT



CALCE PERLA



CALCE CENERE



CORTEN BERICO



MARMO CANOVA

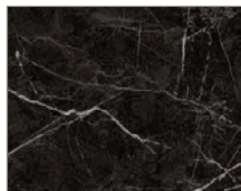

MARMO NERO MARQUINIA

CARATTERISTICHE TECNICHE

- **Piani** con pannello in agglomerato di particelle di legno (UNI EN 309), sp. 25 mm in classe E1 a bassa emissione di formaldeide, nobilitati in melamminico 2 lati con linitura antigraffio. Bordo in ABS raggiato sui 4 lati.
- **Struttura:**
 - Sostegno tavolo con gambe metalliche verniciate a polveri epossidiche, linitura alluminio. Diametro 60 mm, complete di piedini alla base regolabili in altezza. Altezza minimo 780 mm – massimo 810 mm, tali da consentire l'inserimento di una carrozzina.
 - Sostegno tavolo con colonna centrale in metallo verniciato a polveri epossidiche, linitura alluminio. Diametro 80 mm, piastra di base diametro 600 mm e piastra di lissaggio sotto piano. Piedini in gomma per una maggiore stabilità. Altezza 780 mm, tali da consentire l'inserimento di una carrozzina.
 - Sostegno tavolo attesa con gambe metalliche verniciate a polveri epossidiche, linitura alluminio. Diametro 60 mm, complete di piedini alla base regolabili in altezza. Altezza 450 mm.



COD. GBW0008
 QUADRATO CON PIEDINI
 ALLA BASE REGOLABILI
 IN ALTEZZA Ø60 mm
 L950 x P950 x H805 mm



COD. GBT0009
 QUADRATO CON PIEDINI ALLA BASE
 REGOLABILI IN ALTEZZA Ø60 mm
 L950 x P950 x H805 mm

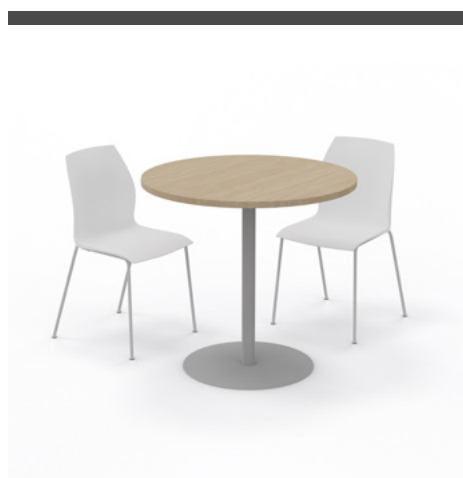

COD. GBT0010
 TONDO COLONNA CENTRALE
 Ø60 mm CON PIASTRA DI BASE Ø600
 mm Ø950 x H805 mm



COD. GBW0013
 RETTANGOLARE CON PIEDINI
 ALLA BASE REGOLABILI
 IN ALTEZZA Ø60 mm
 L950 x P700 x H805 mm



COD. GBW0011
 TONDO CON PIEDINI ALLA BASE
 REGOLABILI
 IN ALTEZZA Ø60 mm
 Ø600 x H475 mm



COD. GBT0012
 QUADRATO CON PIEDINI ALLA BASE
 REGOLABILI IN ALTEZZA Ø 60 mm
 L600 x P600 x H475 mm



Via G.Luraghi
c/o Consorzio il Sole Lotto S
80038 Pomigliano d'Arco (NA)
Italy
+39 081 8692160

www.gardhenbilance.it
info@gardhenbilance.it

**ARREDO
SANITARIO**